

Rocker Panel Molding Package Installation (Instruction ID: 23380505)

Installation Instructions Part Number

23380505

Kit Contents

Qty	Description
1	Molding-Rocker Panel – LH
1	Molding-Rocker Panel – RH
1	Attachment Package-Rocker Panel Molding
1	Front End Spoiler Package (Optional Content)
1	Installation Instructions

Tools Required

Drill

4 mm (11/64") drill bit

5 mm (13/64") drill bit



Rivet Tool

Adhesive: 3M 08609 Urethane, 3M 08682 Primer

Caulk Gun

Masking Tape

Suitable cutting knife

Preliminary Procedure

Rocker Panel Adhesive Tape Modification

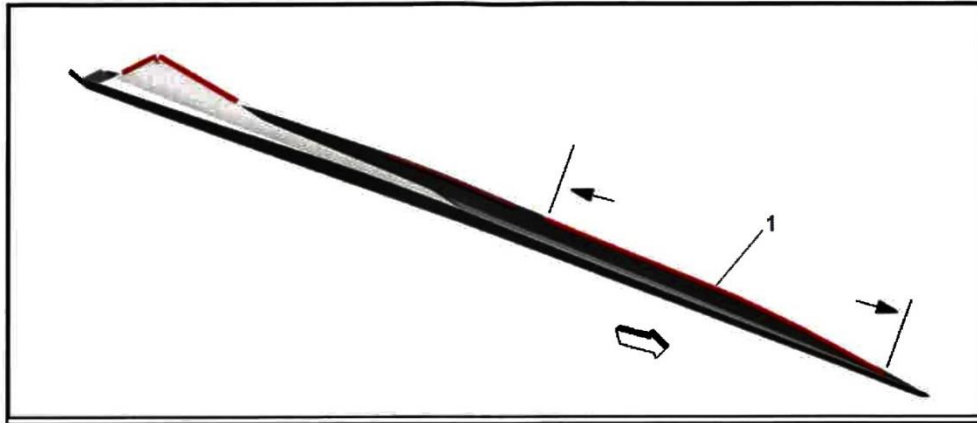

Note: LH side shown, RH side Similar.

1. Verify front section of adhesive tape (1) on rocker panel molding, if adhesive tape looks similar to what is shown, then continue to steps 2 through 4 in this section.

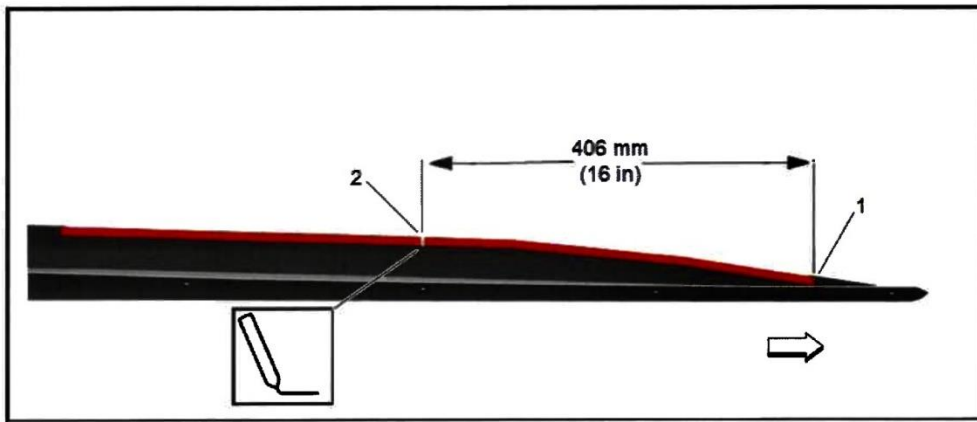

2. From the end of adhesive tape (1) at the front of rocker panel molding, measure 406mm (16 in) and mark a line (2) on adhesive tape liner.

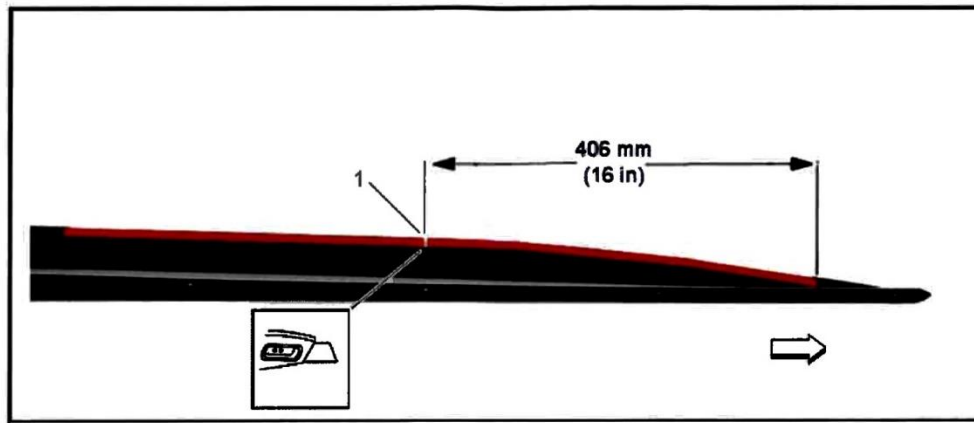

Note: Prior to cutting adhesive tape, peel back adhesive liner from front of rocker panel molding to the previously marked line (1). Leave adhesive liner long at cut to allow pull tab for install.

- Using a suitable cutting knife, cut through the adhesive tape at the previously marked line (1).

Note: Make sure not to cut into rocker panel molding.

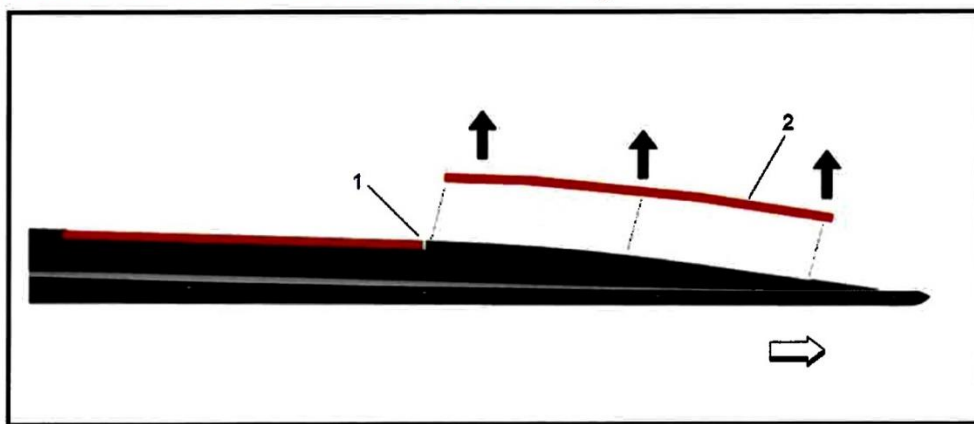

- Remove the section of adhesive tape (2) from the rocker panel molding at the previous cut line (1).

Procedure

Note: Carefully read and understand instructions and components completely before beginning installation.

Note: Wash/clean rocker panels before ground effects installation.

Note: The part and vehicle surface should be 21°C – 32°C (70°F – 90°F) prior to installation. The vehicle should remain inside in a temperature range of 21°C – 32°C (70°F – 90°F) for 1 hour after assembly to allow the adhesive to develop sufficient bond strength.

© 2020 General Motors. All rights reserved.

Note: Keep the vehicle dry for 24 hours after the installation to allow maximum tape and urethane adhesion.

Caution: Ground Effects reduce the vehicle's ground clearance. Enter driveways, bumps and ramps with care.

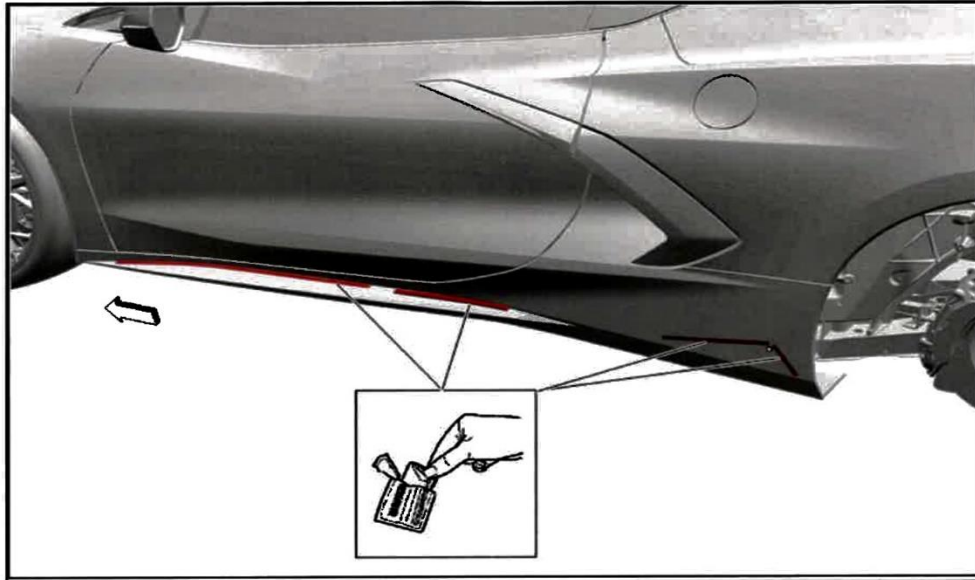

15. Note the area of attachment tape contact to rocker panel. Clean the area with the solvent wipe.

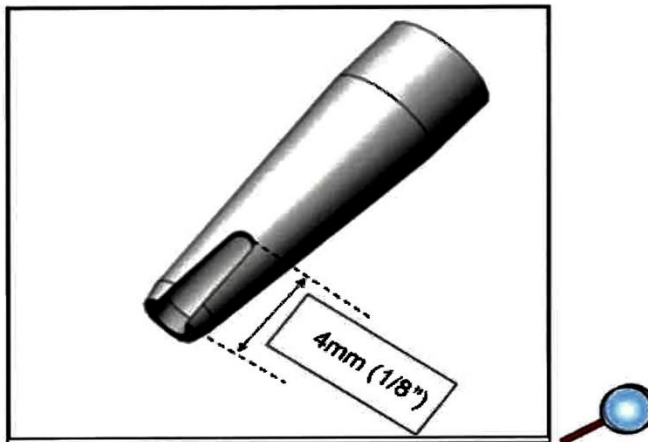

16. Cut the urethane tip 4mm (1/8") as shown.

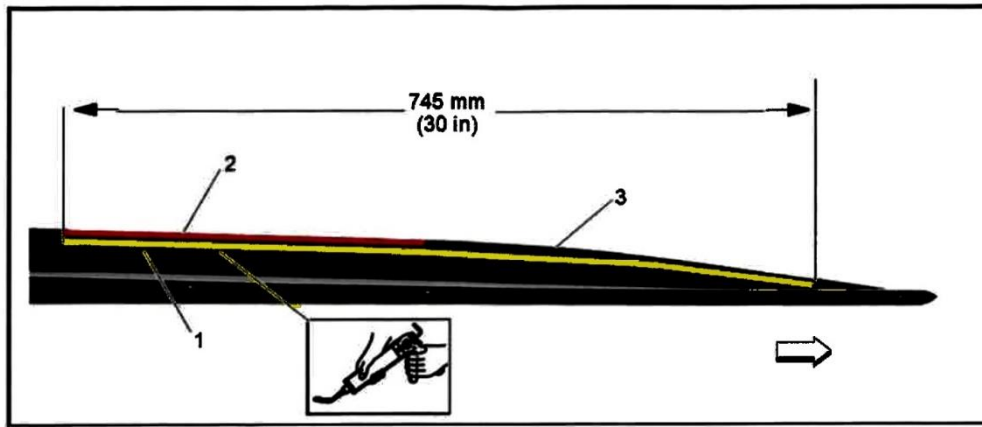

Note: Make sure to confirm adhesive tape area on rocker molding prior to applying primer and urethane. Refer to **Rocker Panel Adhesive Tape Modification** at the beginning of these instructions.

17. Apply 3M 08681 or equivalent primer to rocker molding (3) parallel to tape (2) towards front of rocker molding as shown, allow to dry.
18. Apply a 5mm (13/64") bead of 3M 08609 or equivalent urethane (1) onto the backside of the rocker molding (3) parallel to tape (1) towards front of rocker molding as shown.

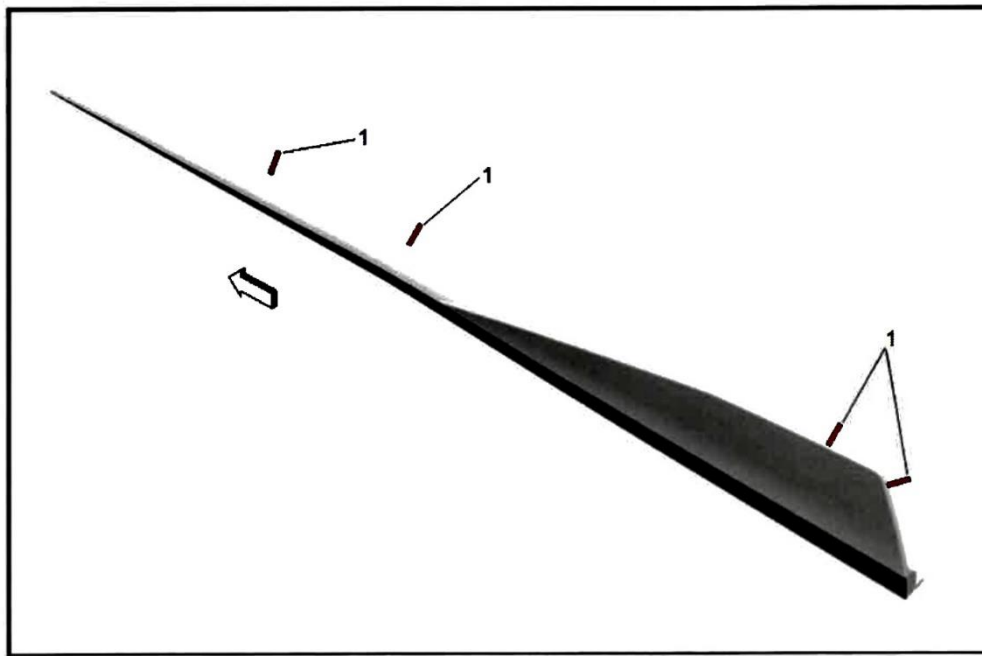

19. Peel back and expose tape liners (1) on the outside of rocker panel molding, **do not fully remove liners.**

© 2020 General Motors. All rights reserved.

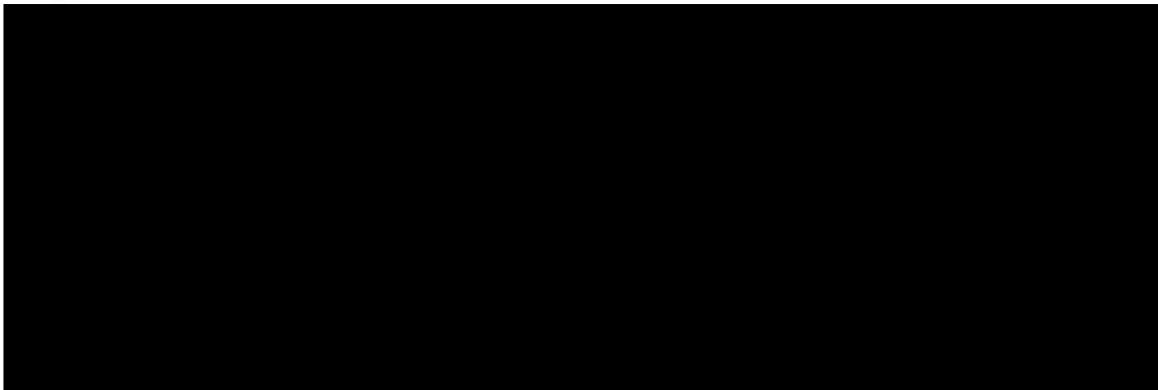
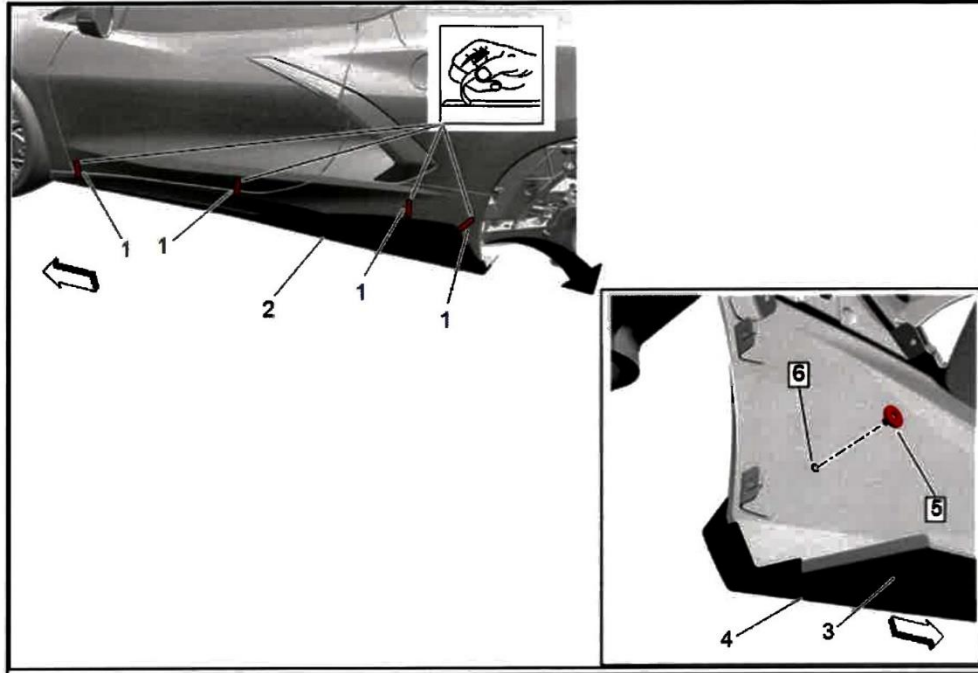

Note: With the vehicle at eye level make sure rocker panel molding is positioned correctly and fits well into the body before pulling out tape liners (1).

- 22. With an assistant hold pressure inward on rocker and carefully pull out the tape liner along the front edge of the rocker panel molding and apply pressure to get good tape wet out.
- 23. Carefully pull out the tape liner along the rear of the rocker panel molding and apply pressure to get good tape wet out.



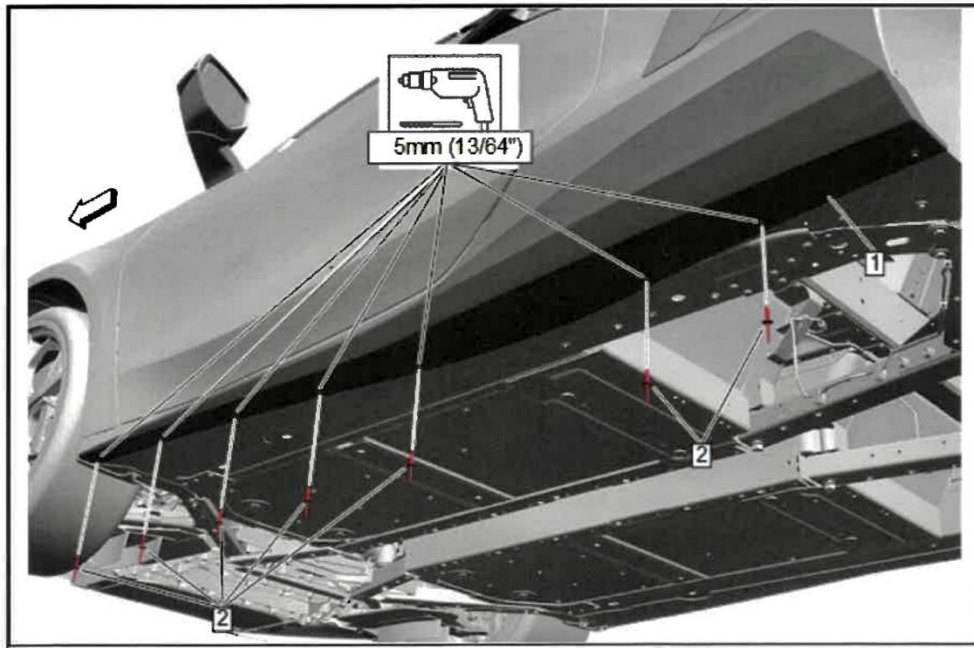
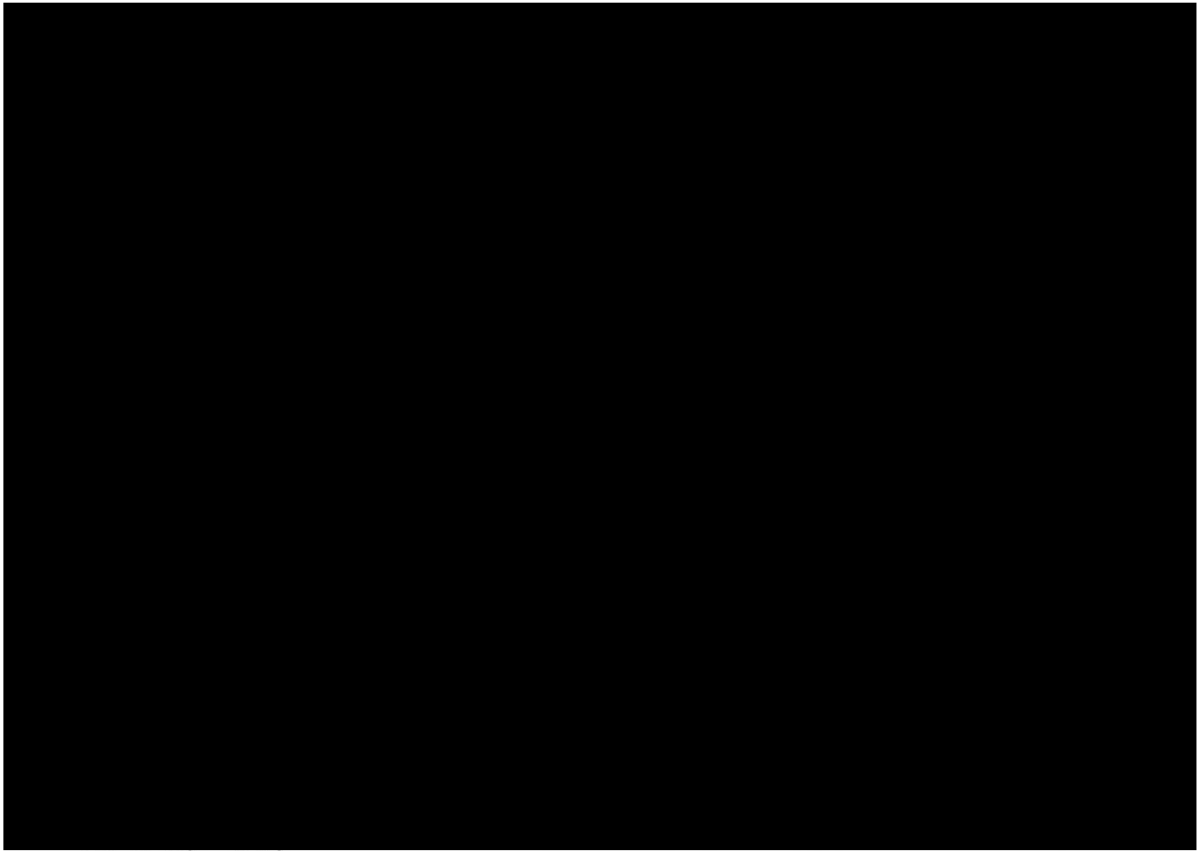

28. Using a 5 mm (13/64") drill bit, drill seven holes into the underbody using the existing holes in rocker panel molding (1).
29. Install the supplied rivets (2) into the previously drilled holes.
30. Repeat rocker install steps for opposite side.
31. Reinstall the rear wheel and tire assemblies. Refer to [Tire and Wheel Removal and Installation](#) in Vehicle Service Manual.
32. If front spoiler is part of purchased accessory kit, refer to the installation instructions below for front spoiler installation. If front spoiler is not being installed, lower the vehicle.